



pimbg.com

PRODUCER OF MACHINES AND EQUIPMENT FOR THE FOOD INDUSTRY
ПРОИЗВОДИТЕЛ НА МАШИНИ И СЪОРЪЖЕНИЯ ЗА ХРАНИТЕЛНАТА ПРОМИШЛЕНОСТ



**CHOCOLATE PRODUCTS /
KETCHUP / MAYONNAISE /
FINE PASTA PRODUCTS**

**ШОКОЛАДОВИ ПРОДУКТИ /
КЕТЧУП / МАЙОНЕЗА / МАКАРОНИ ИЗДЕЛИЯ**

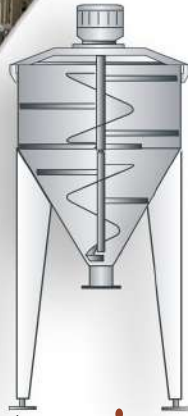

Съд буферен
Buffer container

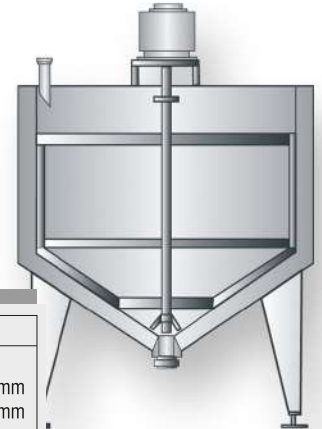

Съд за прахообразни материали
Container for powder substances

Technical parameters

Обем/ Volume	500 l
Габаритни размери/Overall dimensions:	
- диаметър/ Diametre	1000 mm
- ширина/ Width	1080 mm
- височина/ Height	2420 mm
Инсталирана мощност/ Inst.Power	1.5 kW

Technical parameters

Обем/ Volume	2000 l
Габаритни размери/Overall dimensions:	
- диаметър/ Diametre	1720 mm
- височина/ Height	2900 mm
Инсталирана мощност/ Inst.Power	2.2 kW

Смесител за масло
Butter mixer



Technical parameters

Обем/ Volume	2000 l
Габаритни размери/Overall dimensions:	
- диаметър/ Diametre	1720 mm
- височина/ Height	2200 mm
Инсталирана мощност/ Inst.Power	2.2 kW

Машина за шоколадов кувертюж
Machine for chocolate couverture



Technical parameters

Обем/ Volume	2000 l
Габаритни размери/ Overall dimensions:	
- диаметър/ Diametre	1640 mm
- ширина/ Width	2300 mm
- височина/ Height	2900 mm
Обща инстал. мощност/ Total Inst.Power	25 kW

Съд за хомогенизиране на смеси
Turbo mixer



Technical parameters

Обем/ Volume	100 l	300 l
Габаритни размери/Overall dimensions:		
- диаметър/ Diametre	500 mm	734 mm
- ширина/ Width	540 mm	780 mm
Обща инстал.мощност/ Total Inst.Power	3 kW	6.5/8 kW



CHOCOLATE PRODUCT PRODUCTION LINE
(chocolate cakes, waffles, biscuits,
coated nuts, figs etc.)



Машини за обмазване на шоколадови изделия
Machines for daubing chocolate products



Technical parameters

Производителност/Capacity	16 блата/16 pieces/min
Обем на ваната/Capacity of the tub	129 l
Габаритни размери/Dimensions, mm	
- дължина/length	1220 mm
- ширина/width	1200 mm
- височина/height	1850 mm
Дължина на гитер лентата/Length of the gitter band	2600 mm
Ширина на гитер лентата/ Width of the gitter band	800 mm
Инст. мощност/Installed power	4,5 kW

Машина за тункване на шоколадови изделия
Coating machine

Technical parameters

Производителност/Capacity	24 блата/24 pieces/min
Обем на ваната/Capacity of the tub	129 l
Габаритни размери/Dimensions, mm	
- дължина/length	2400 mm
- ширина/width	1200 mm
- височина/height	1850 mm
Дължина на гитер лентата/Length of the gitter band	3650 mm
Ширина на гитер лентата/ Width of the gitter band	800 mm
Инст. мощност/Installed power	3,5 kW



Машина за печене на вафлени кори
Wafer sheets baking machine

Technical parameters

Изпичащи клещи/ Baking tongs	40 бр./pcs
Производителност/Capacity	850 бр./ч
Габаритни размери/Dimensions mm	
- дължина/length	8700 mm
- широчина/width	1700 mm
- височина/height	2000 mm
Обща инст. мощност/Total inst. power	132 kW



Машина за рязане на вафли - пневматична
Waffle cutting machine - pneumatic

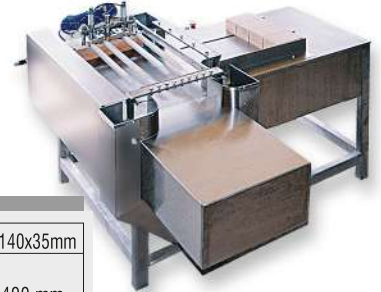
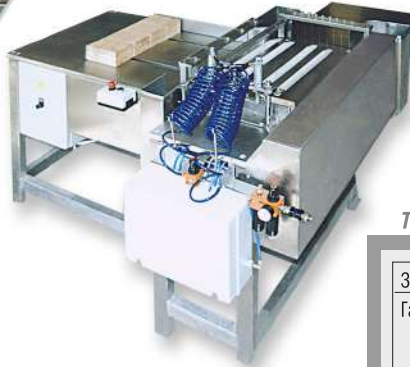

Technical parameters

За вафли с размер/For waffles size	115x35mm, 140x35mm
Габаритни размери/Dimensions, mm	
- дължина/length	1400 mm
- ширина/width	1950 mm
- височина/height	1170 mm
Инст. мощност/Installed power	0,1 kW

Лентов охладителен тунел
Belt cooling tunnel



Technical parameters

Условна дължина/Conditional length	10 m;	20 m
Габаритни размери/Overall dimensions		
- широчина/width		1650 mm
- височина/height		1300 mm
Инст. мощност/Inst. power	8 kW;	16 kW



Транспортър шнеков за сухи смеси
Worm transporter for dry mixtures

- Допълнителни съоръжения/ Additional equipment:
- Мелница за ядки/ Nut grinder;
 - Мелница за вафлени кори/ Wafer grinder.

**ЛИНИЯ И ОБОРУДВАНЕ ЗА ПРОИЗВОДСТВО
НА МАКАРОНИ И ИЗДЕЛИЯ**
**LINE AND EQUIPMENT FOR MANUFACTURE
OF FINE PASTA PRODUCTS**



Съд под вакуум с бъркалка
Vacuum container with ladle

Съд за готов продукт
Container for the ready-made product

Съд буферен
Buffer container



Дозираща машина
Dosing machine

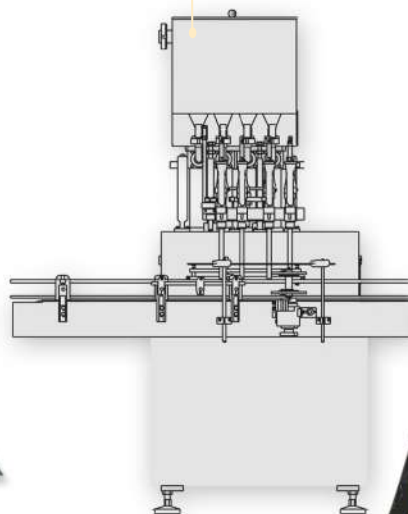

Помпа винтова
Screw-pump

Вакуум-помпа
Vacuum-pump

Помпа винтова
Screw-pump

Хомогенизатор
Homogenizer

Technical parameters

Производителност/Сарасити	1000 kg/shift (кр/смяна)
Габаритни размери/Overall dimensions	3600/1200/2300 mm
Необходима работна площ/ Working area required for the personnel	30 m ²
Обща инст. мощност/Total Inst. Power	10 kW

Деаератор поточен
Line deaerator



Резервоар с бъркалка
Container with mixer



Съд буферен
Buffer container



Технологична линия
Technological line



Technical parameters

Производителност/Capacity	1000 kg/h (кг/час)
Габаритни размери/Overall dimensions	6500/9000 mm
Необходима работна площ/ Working area required for the personnel	60 m ²
Обща инстал. мощност/Total Inst. Power	16 kW

Съд с изолация
Container with isolation



Погревател с пастъризатор
Heater with pasteurizer



**ЛИНИЯ И ОБОРУДВАНЕ ЗА ПРОИЗВОДСТВО
НА МАКАРОНЕНИ ИЗДЕЛИЯ**
**LINE AND EQUIPMENT FOR MANUFACTURE
OF FINE PASTA PRODUCTS**



Машина за разбъркване МБ 250
Mixing machine

Technical parameters

Производителност/ Capacity	150-200 kg/h (кг/час)
Габаритни размери/ Overall dimensions	1300/600/1030 mm
Вместимост/ Volume	250 l
Инсталирана мощност/ Inst. Power	1.5 kW
Маса/ Weight	120 kg

Машина за пресоване на макаронени изделия
Extruder for pasta

Technical parameters

Производителност/ Capacity	100 kg/h (кг/час)
Габаритни размери/ Overall dimensions	1400/700/1700 mm
Диаметър на матрицата/ Matrix diameter	140 mm
Потребление на вода/ Water consumption	70 l/h
Инсталирана мощност/ Inst. Power	7 kW
Маса/ Weight	450 kg



Сушилня за макаронени изделия
Drying Oven

Technical parameters

Производителност/ Capacity	400 kg/cycle (кг/цикъл)
Габаритни размери/ Overall dimensions	3500/1455/2400 mm
Вместимост/ Volume	4 колички+104 скари 4 carriages+104 grates
Маса/ Weight	530 kg





PIM[®] Ltd *Bulgaria*

6, Vassil Levski Blvd., 6300 Haskovo, Bulgaria
Tel. +359 38 664601, Fax + 359 38 664604
e-mail: pim@pimbg.com, pimbg.com

